

GS EVO INOX 25 1150x525

STAINLESS STEEL



GS EVO INOX

The GS EVO INOX hand pallet truck is the ideal tool to handle loads in areas where high hygienic and cleaning standards are strictly enforced.

Manufactured entirely in AISI 304 electropolished stainless steel, it is suitable for environments such as the chemical, pharmaceutical or food & beverage industry.



HYDRAULIC UNIT

The GS EVO INOX pump is made of stainless steel to offer maximum resistance to humidity and oxidation. Designed with extreme care of details in order to have superior characteristics and features, it includes:

- **Monolithic design:** resistant and reliable one-piece housing to protect all components avoiding any accidental damages. Pump housing is processed with CNC machines to achieve high precision tolerances and high accuracy.
- **Chromed piston rod and oil seal:** in order to avoid rust and prevent oil leakage during the use.
- **Maximum pressure valve:** safety device that protects the transpallet against overloads.
- **PROPORTIONAL LOWERING VALVE:** lowering speed can be proportionally controlled according to the lever position on the tiller. Perfect working tool to carry fragile and delicate loads like crystal, glass and ceramics.



TILLER

3D INOX Superior Ergonomic shape tiller. This tiller has a special 3D design, with enhanced ergonomics. Compared to a conventional tiller, this shape allows the operator to have a good position when pushing the loads with maximum efficiency without fatigue. This thanks to two large grasping side areas specifically designed to have a correct position during operation of the truck.



ELECTROPOLISHING

The use of Inox AISI 304, combined with an electropolishing surface treatment, provides the machine with better appearance. Optimum resistance to corrosion also guarantees maximum hygiene.

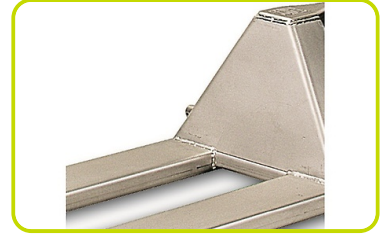

Description

1.1 Manufacturer	PR INDUSTRIAL		
1.3 Drive	Manual		
1.4 Operator type	Pedestrian		
1.5 Load capacity	Q	kg	2500
1.6 Load centre distance	c	mm	600
1.8 Load axle to end forks	x	mm	932
1.9 Wheel base	y	mm	1192

Weights

2.1 Service weight	kg	69
2.2 Axle load, laden rear	kg	1827
2.2 Axle load, laden front	kg	742
2.3 Axle load, unladen rear	kg	23
2.3 Axle load, unladen front	kg	46

Tyres/Chassis

3.1 Tyres: front wheels	NYLON		
3.1 Tyres: rear wheels	NYLON		
3.2 Tyre size: Steering wheels - Diameter	mm	200	
3.2 Tyre size: Steering wheels - Width	mm	50	
3.3 Tyre size: Load rollers - Diameter	mm	82	
3.3 Tyre size: Load rollers - Width	mm	60	
3.5 Tyre size: rear wheels - Q.ty (X=driven)	nr	4	
3.5 Tyre size: front wheels - Q.ty (X=driven)	nr	2	
3.6 Tread, front	b10	mm	155
3.7 Tread, rear	b11	mm	375

Dimensions

4.4 Lift height	h3	mm	115
4.9 Height of tiller in drive position max	h14	mm	1185
4.9 Height of tiller in drive position min	h14	mm	710
4.15 Height, lowered	h13	mm	85
4.19 Overall length	l1	mm	1550
4.20 Length to face of forks	l2	mm	400
4.21 Overall width (front/rear)	b1/b2	mm	525
4.22 Fork dimensions - Thickness	s	mm	50
4.22 Fork dimensions - Width	e	mm	150
4.22 Fork dimensions - Length	l	mm	1150
4.25 Forks width	b5	mm	525
4.32 Ground clearance, centre of wheelbase	m2	mm	35
4.34 Aisle width	Ast	mm	2048
4.35 Turning radius	Wa	mm	1367

Performance data

5.2 Lifting speed laden	strokes	12
5.2 Lifting speed unladen	strokes	12

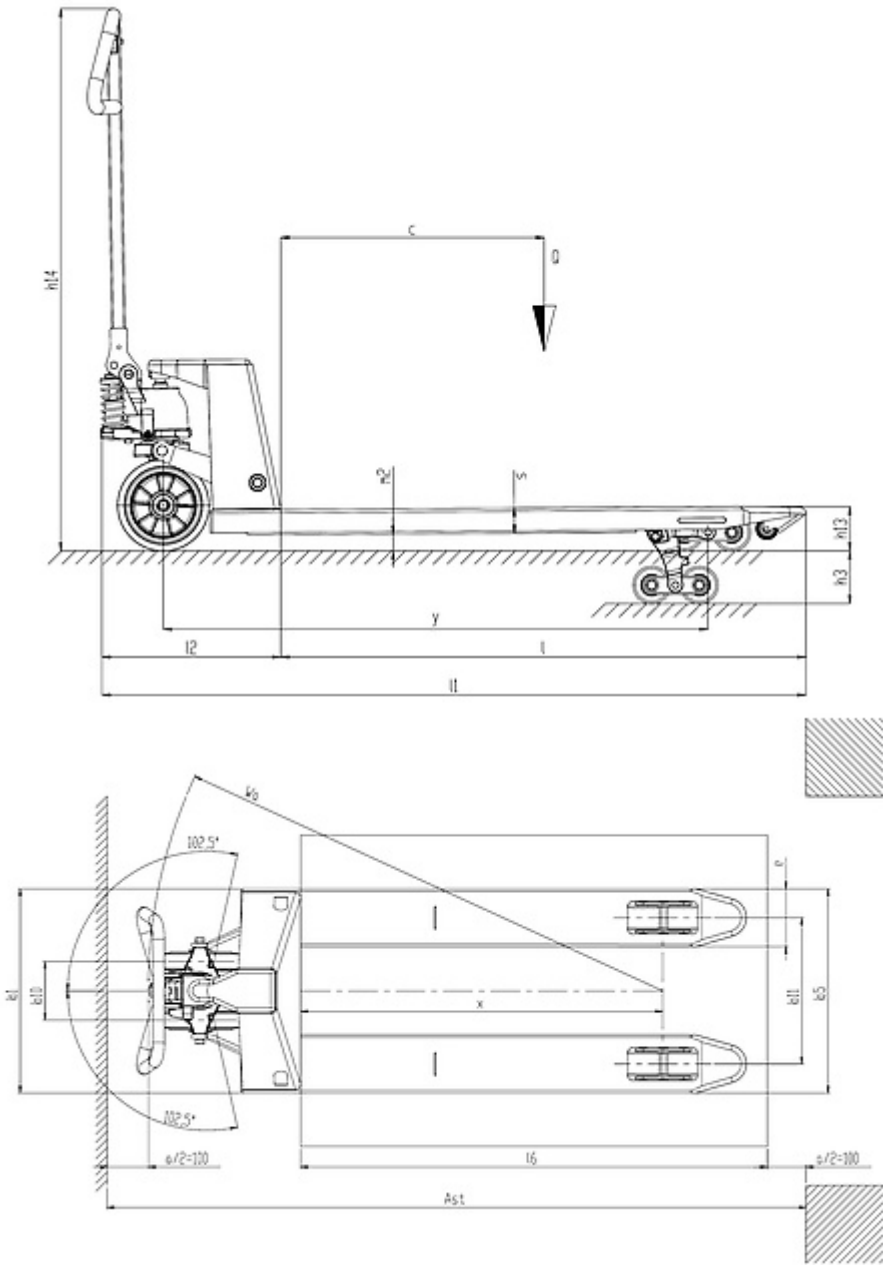

The information is aligned with the Data file at the time of download.
Printed on 30/04/2026 (ID 18968)

©2026 | PR Industrial S.r.l. – Loc. Il Piano – 53031 Casole d'Elsa (SI) – ITALY. Company subject to the management and coordination of Generac Power Systems Inc. | All rights reserved | Image shown may not reflect actual package. Specifications subject to change without notice

