

MANUAL PALLET STACKER

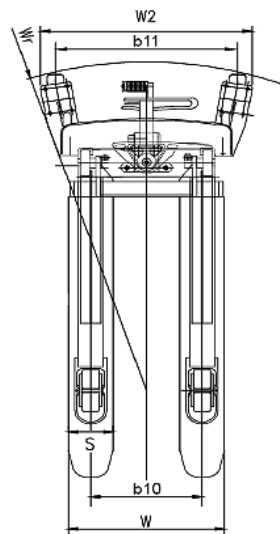

Product code:
BDMPS1000

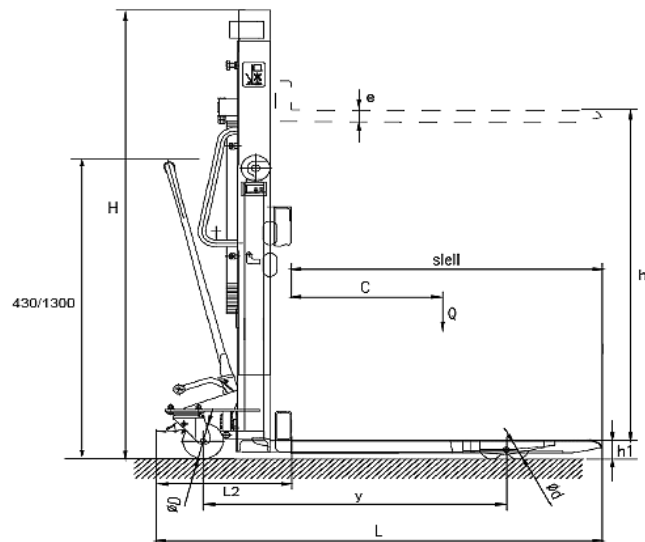

Product

Description	Suffix on diagram	Measurement	
Drive		Manual	
Operator Type		Pedestrian	
Load Capacity	Q	1000	kg
Load Centre Distance	C	600	mm
Wheel Base	y	1150	mm
Finish			
Body		RAL1003 (Yellow)	RAL
Platform		Black	
Pump		Black	
Weights			
Product Weight		187 ± 2	kg
Tyres/ Chassis			
Driven Wheel Type		Nylon	
No. of Driven Wheels		2	
Driven Wheel Dia	ØD x Width	180 x 50	mm
Roller Wheel Type		Nylon	
No. of Rollers		4	
Roller Dia.	ød x Width	78 x 60	mm
Tread, Front	b10	400	mm
Tread, Rear	b11	650	mm
Dimensions			
Lift Height	h	1600	mm
Mast Lowered Height	H	2010	mm
Mast Extend Height	H	2010	mm
Minimum Fork Height	h1	85 ± 5	mm
Fork Length	L1	1150	mm
Overall Length	L	~1650	mm
Length to Face of Forks	L2	520	mm
Fork Width	W	560	mm
Overall Width	W2	780 ± 10	mm
Fork Dimensions - Height	e	55 ± 3	mm
Fork Dimensions - Width	S	160	mm
Fork Dimensions - Length	slen	1150	mm
Distance between Forks (Inside)		240	mm
Ground Clearance - Lowered		25~30	mm
Minimal Turning Radius	Wa	1590	mm
Height of Handle, Min./Max.		430/1300	mm
Performance			
Lifting Speed		≥16	Strokes
Lowering Speed		Controllable	