

MINI PLATFORM STACKER

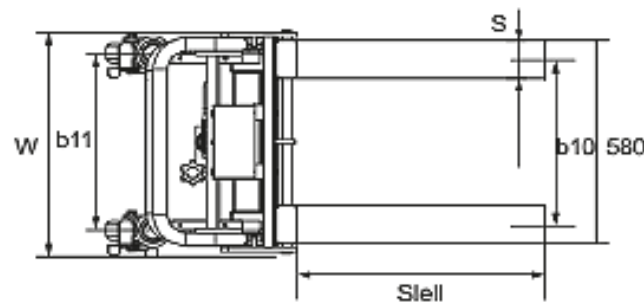

Product code:
BDMPLS400

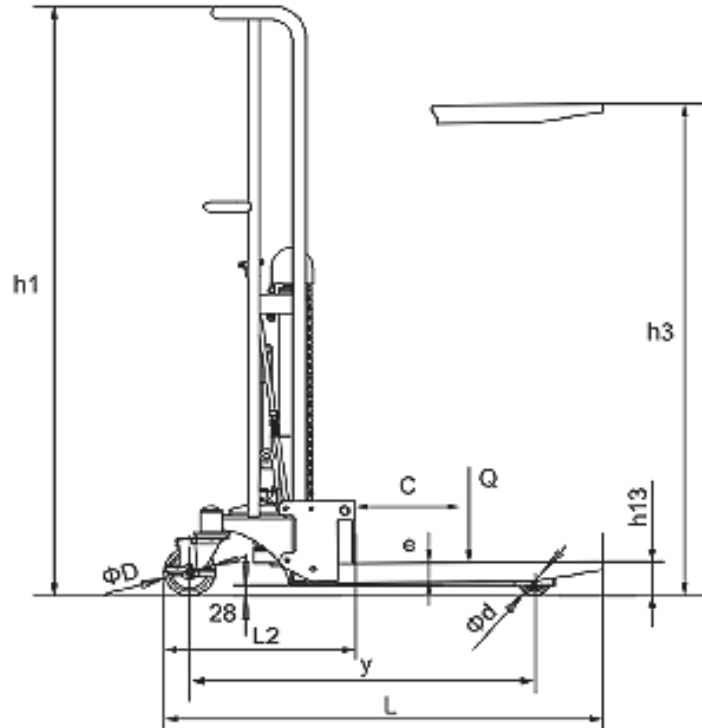

Product

Description	Suffix on diagram	Measurement	
Drive		Manual	
Operator Type		Pedestrian	
Load Capacity	Q	400	kg
Load Centre Distance	C	300	mm
Wheel Base	y	765 ± 2mm	mm
Finish			
Body		RAL1003 (Yellow)	RAL
Platform		Black	
Pump		Black	
Weights			
Product Weight		93 ± 1	kg
Tyres/ Chassis			
Driven Wheel Type		PU	
No. of Driven Wheels		2	
Driven Wheel Dia	ØD	125*50 (±1mm)	mm
Roller Wheel Type		PU	
No. of Rollers		2	
Roller Dia.	ød	75*35(±1mm)	mm
Tread, Front	b10	412	mm
Tread, Rear	b11	474	
Dimensions			
Table Dimension		650*580 *3	mm
Lifting Height	h3	1500 (±5mm)	mm
Mast Height	h1	1750 ± 5	mm
Fork Lowered	h13	85-90(±2mm)	mm
Overall Length	L	1080 ± 5	mm
Length to Face of Forks	L2	550	mm
Overall Width	W	590 ± 2	mm
Fork Dimensions - Height	e	50 ± 2	mm
Fork Dimensions - Width	S	105 ± 2	mm
Fork Dimensions - Length	Stell	650	mm
Fork Thickness		6	mm
Ground Clearance - Lowered		28	mm
Performance			
Lift Speed		77-83	strokes

Note: Illustrations not to scale